

WiFly GSX 802.11 b/g Wireless LAN Module



Features

- Qualified 2.4GHz IEEE 802.11b/g transceiver
- High throughput, 1Mbps sustained data rate with TCP/IP and WPA2
- Ultra-low power - 4uA sleep, 40mA Rx, 210mA Tx (max)
- Small, compact surface mount module
- On board ceramic chip antenna and U.FL connector for external antenna
- 8 Mbit flash memory and 128 KB RAM
- UART hardware interface
- 10 general purpose digital I/O
- 8 analog sensor interfaces
- Real-time clock for wakeup and time stamping
- Accepts 3.3V regulated or 2-3V battery
- Supports Adhoc connections
- On board ECOS -OS, TCP/IP stacks
- Wi-Fi Alliance certified for WPA2-PSK
- FCC / CE/ ICS certified and RoHS compliant.
- Industrial (RN-131G) and commercial (RN-131C) grade temperature options

- Home Automation
- Medical device monitoring

Description

The WiFly GSX module is a stand alone, embedded wireless 802.11 networking module. Because of its small form factor and extremely low power consumption, the RN-131G is perfect for mobile wireless applications such as asset monitoring, GPS tracking and battery sensors. The WiFly GSX module incorporates a 2.4GHz radio, processor, TCP/IP stack, real-time clock, crypto accelerator, power management and analog sensor interfaces. This complete solution is preloaded with software to simplify integration and minimizes development of your application. In the simplest configuration the hardware only requires four connections (PWR, TX, RX, GND) to create a wireless data connection. Additionally, the sensor interface provides temperature, audio, motion, acceleration and other analog data without requiring additional hardware. The WiFly GSX module is programmed and controlled with a simple ASCII command language. Once the WiFly GSX is setup it can scan to find an access point, associate, authenticate and connect over any Wifi network.

Applications

- Remote equipment monitoring
- Telemetry
- Industrial sensors and controls

Block Diagram

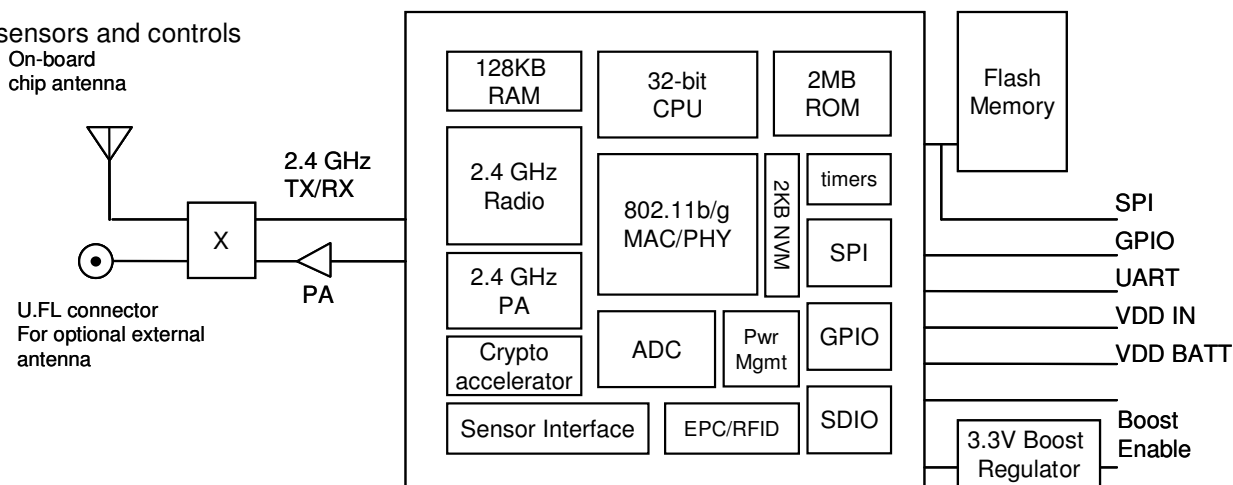

Overview

- Host Data Rate up to 1 Mbps for UART
- Intelligent, built-in power management with programmable wakeup
- Can be powered from regulated 3.3-3.7V source or 2.0-3.0V batteries
- Real time clock for time stamping, auto-sleep and auto-wakeup
- Configuration over UART using simple ASCII commands
- Telnet configuration over WiFi
- Over the air firmware upgrade (FTP)
- Memory 128 KB RAM, 2MB ROM, 2 KB battery-backed memory, 8 Mbit Flash.
- Secure WiFi authentication WEP-128, WPA-PSK (TKIP), WPA2-PSK (AES)
- Built in networking applications DHCP, UDP, DNS, ARP, ICMP, TCP, sockets
- 802.11 power save and roaming functions

Environmental Conditions

Parameter	RN-131G	RN-131C
Temperature Range (Operating)	-30 °C ~ +85 °C	0 °C ~ +70 °C
Temperature Range (Storage)	-40 °C ~ +85 °C	-40 °C ~ +85 °C
Relative Humidity (Operating)	≤90%	≤90%
Relative Humidity (Storage)	≤90%	≤90%

Electrical Characteristics

Supply Voltage	Min	Typ.	Max.	Unit
Supply Voltage VDD	3.0	3.3	3.7	VDC
Supply Voltage (VBATT option)	2.0	3.0	3.3	VDC
Pin 21 switched 3.3V output			150	ma
Digital Input				
Input logic HIGH VIH	2.3V			VDC
Input logic LOW VIL			1.0V	VDC
Digital Output drive				
PIO 4,5,6,7,8		24		ma
PIO 9,10,11,12,13		8		ma
Power consumption				
Sleep		4		uA
Standby (doze)	-	15	-	mA
Connected (idle, RX)		40		mA
Connected (TX)		140	212	mA

Analog Sensor Inputs

Parameter	Value
Sense 0,1,2,3 wakeup detect threshold	500mV
AD sense 0-7 measurement range	0-400mV
Precision	14 bits = 12uV
Accuracy	5% un-calibrated, .01% calibrated
Minimum conversion time	35uS (5kHz over wifi)
Sensor Power (pin 33) output resistance 3.3V	10 ohms, max current = 50mA

Radio Characteristics

Parameter	Specifications
Frequency	2402 ~ 2480MHz
Modulation	802.11b compatibility : DSSS(CCK-11, CCK-5.5, DQPSK-2, DBPSK-1) 802.11g : OFDM (default)
Channel intervals	5MHz
Channels	1 - 14
Transmission rate (over the air)	1 – 11Mbps for 802.11b / 6 – 54Mbps for 802.11g
Receive sensitivity	-85dBm typ.
Output level (Class1)	+18dBm
Maximum RF input to U.FL connector	10 dBm

Typical Application Schematic

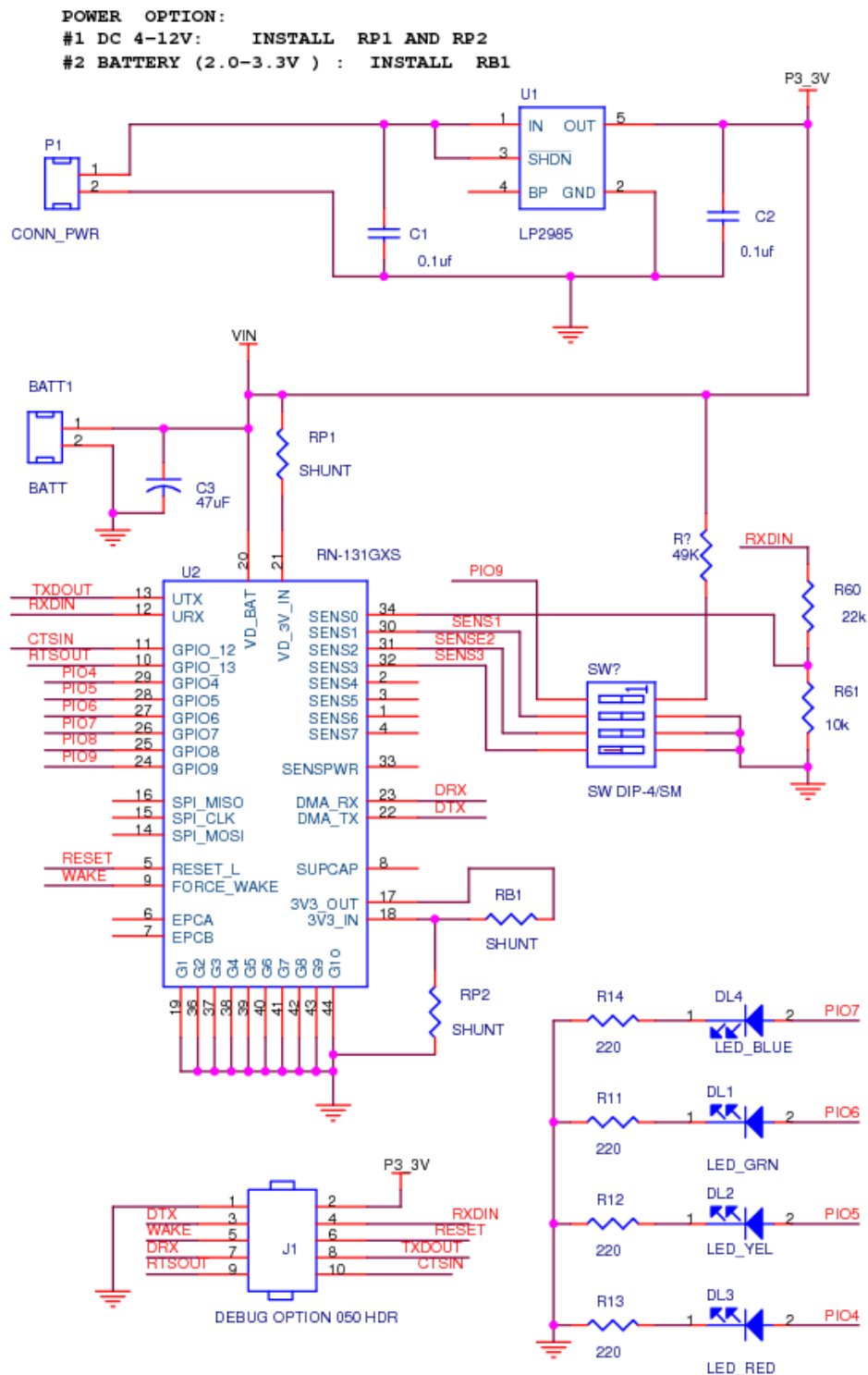

Pin Description

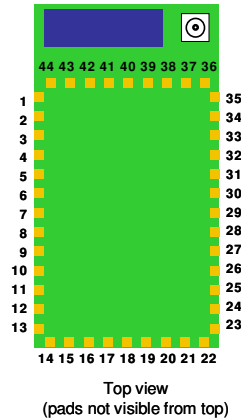

Pin	Name	Description	Default
1	SENSOR-6	Sensor interface, analog input to module, 1.2V	No connect
2	SENSOR-4	Sensor interface, Analog input to module, 1.2V	No connect
3	SENSOR-5	Sensor interface, Analog input to module, 1.2V	No connect
4	SENSOR-7	Analog input to module, 1.2V	No connect
5	RESET	Module reset, Active Low, reference to VDD-BATT, 160 usec pulse	Pull up
6	EPC-ANT-A	EPC port, RFID antenna A	No connect
7	EPC-ANT-B	EPC port, RFID antenna B	No connect
8	SUPERCAP	Balance center pin voltage on stacked super capacitors, Analog 3.3V	No connect
9	FORCE_AWAKE	Force the module to wakeup, input to module, 31us min. pulse	
10	GPIO-13	UART RTS flow control, 8mA drive, 3.3V tolerant	
11	GPIO-12	UART CTS flow control, 8mA drive, 3.3V tolerant	
12	UART-RX	RX to the module, 8mA drive, 3.3V tolerant	
13	UART-TX	TX from the module, 8mA drive, 3.3V tolerant	
14	SPI-MOSI	SPI master data out (Contact Roving Networks for details)	No connect
15	SPI-CLK	SPI clock, (Contact Roving Networks for details)	No connect
16	SPI-MISO	SPI master data in (Contact Roving Networks for details)	No connect
17	3.3V-REG-OUT	boost regulator control output, connect to 3.3V-REG-IN to enable	No connect
18	3.3V-REG-IN	boost regulator control input, connect to 3.3V-REG-OUT to enable	GND to disable
19	GND	Ground	
20	VDD-BATT	Battery input, 2.0-3.3V with boost regulator in use, 3.0-3.7V otherwise	
21	VDD-IN	3.3 to 3.7 voltage, do not connect when boost regulator is in use	
22	DMA-TX	Debug port *(apply 100K pulldown if ultra low sleep power reqd)	HIGH Z
23	DMA-RX	Debug port	No connect
24	GPIO-9	Restore factory resets, 8mA drive, 3.3V tolerant	INPUT
25	GPIO-8	GPIO, 24mA drive, 3.3V tolerant	GP output
26	GPIO-7	GPIO, 24mA drive, 3.3V tolerant	GP output
27	GPIO-6	Connection STATUS, 24mA drive, 3.3V tolerant	LED output
28	GPIO-5	Data transfer STATUS, 24mA drive, 3.3V tolerant	LED output
29	GPIO-4	Association STATUS, 24mA drive, 3.3V tolerant	LED output
30	SENSOR-1	Sensor interface, analog input to module, 1.2V	
31	SENSOR-2	Sensor interface, analog input to module, 1.2V	
32	SENSOR-3	Sensor interface, analog input to module, 1.2V	
33	SENSE-PWR	Voltage output from module to power external sensors, 3.3V	
34	SENSOR-0	Wakeup from external condition	
35	NO CONNECT		No connect
36-44	GND	Must be connected for proper antenna performance	

Physical Dimensions

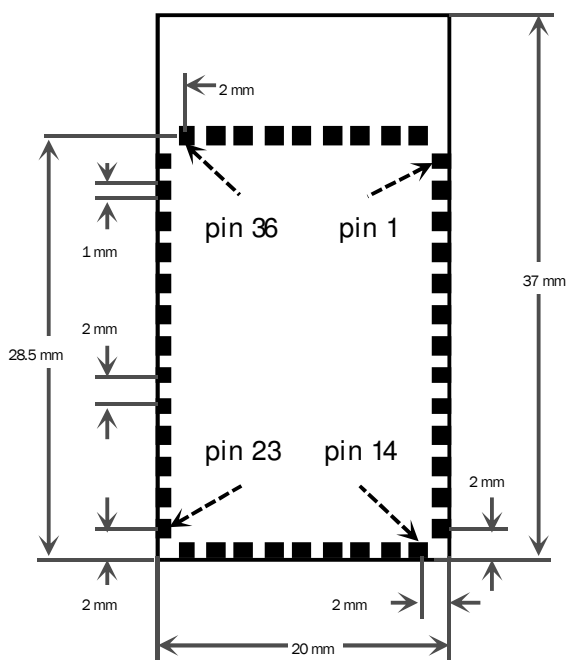
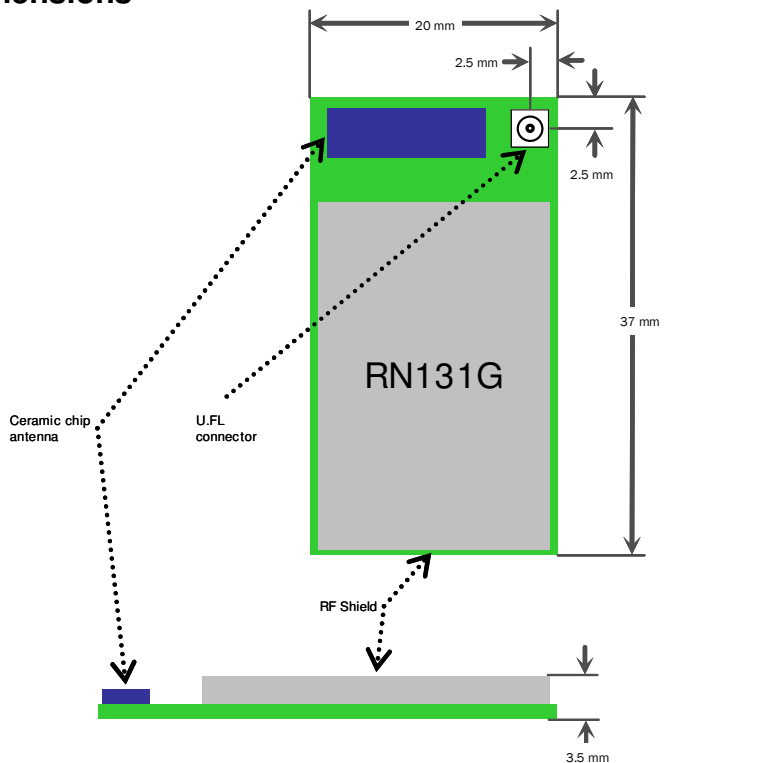

Bottom view

Design Concerns

1. **Minimizing radio interference.** When integrating the WiFly module with on board chip antenna make sure the area around the chip antenna end the module protrudes at least 6mm from the mother board PCB and any metal enclosure. If this is not possible use the on board U.FL connector to route to an external Antenna.

The 8.5 mm area under the antenna end of the module should be keep clear of metallic components, connectors, vias, traces and other materials that can interfere with the radio signal.

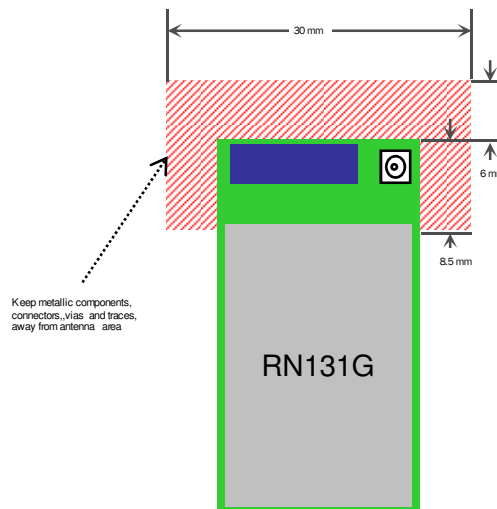

Top view

2. **Proper grounding.** For the module antenna to function pins 36- to 44 must be connected to GND. We suggest you place module such that 0.5mm of these pads is exposed. This provides access for soldering pins 36 through 44 from below and provides ample clearance of the antenna from the PCB.

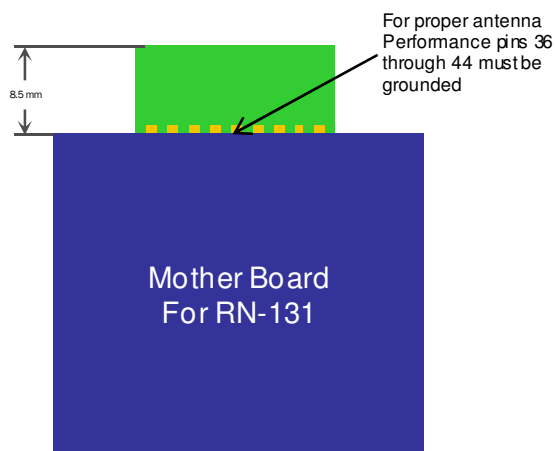

Bottom view

3. **Solder Reflow.** Reflow temperature must not exceed 220C.

To reflow solder the RN-131G and RN-131C module onto a PCB Roving recommends a RoHS compliant solder paste equivalent to the NIHON ALMIT paste or OMNIX OM-310 solder paste from Alpha metals.

Use no clean Flux, Do NOT water wash!

Manufacturer	Alpha Metals http://www.alphametals.com	NIHON ALMIT Co. LTD http://almit.co.jp
Part Number	OMNIX OM-310	LFM-70W INP
Metal Composition	SAC305 (96.5% Sn, 3% Ag, 0.5% Cu)	88% Sn, 3.5% Ag, 0.5% Bi, 8% In
Temp. Liquidus	~220°C	~215°C

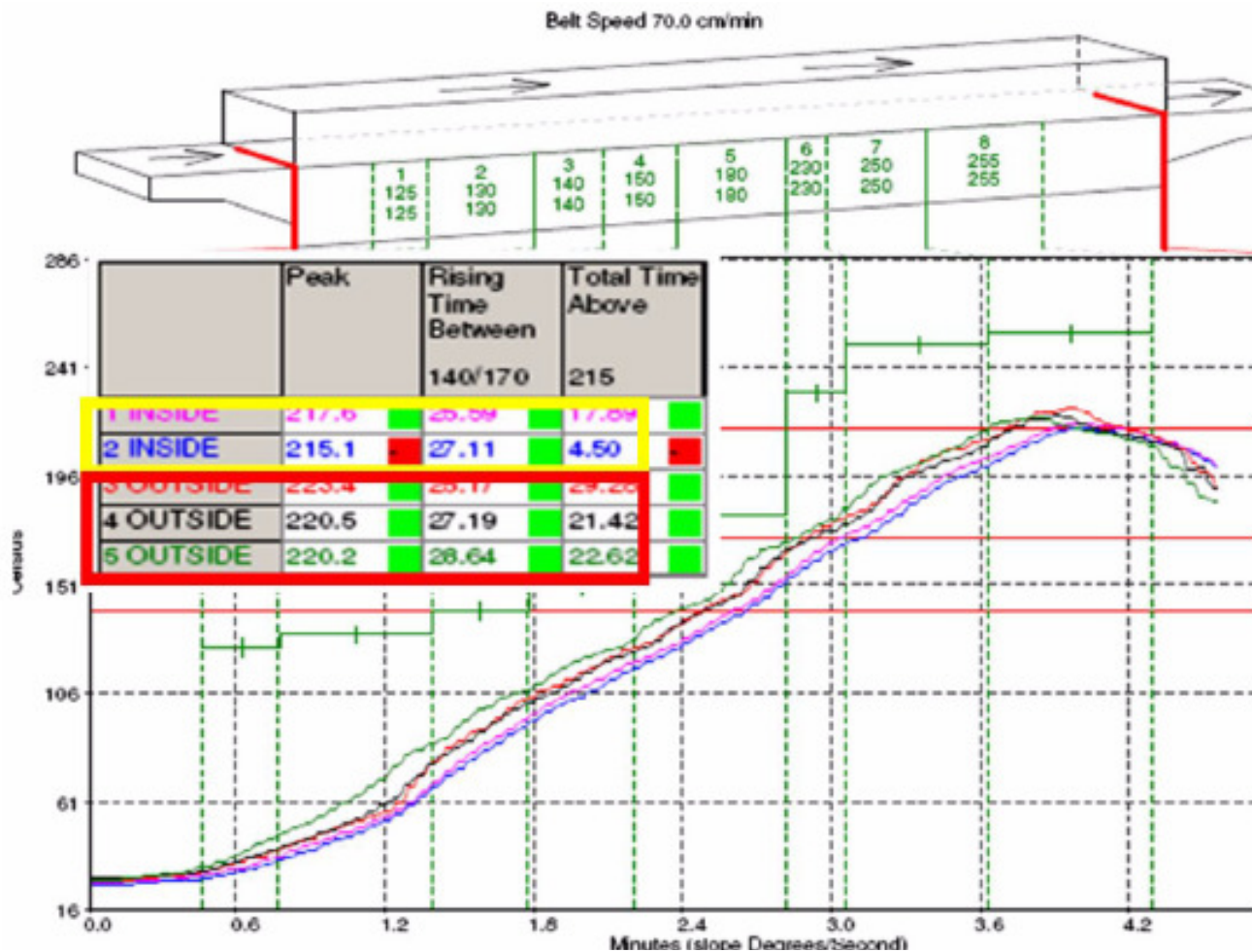

4. **U.FL connector.** Use Hirose U.FL connector **U.FL-R-SMT** to for connecting external antennas. See Roving Networks U.FL to SMA cable. Part number: RN-UFL-SMA6

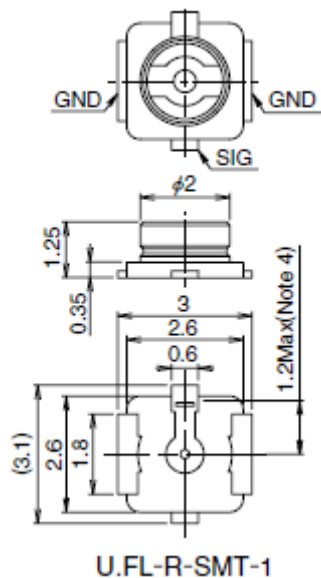

5. **Connection Status.** GPIO-4, GPIO-5, GPIO-6 are available to drive a status LEDs. GPIO-6 indicates TCP/IP connection status. This signal is ON high for an active connection, toggles fast to indicate no IP address and toggles slow indicates IP address OK but not connection. GPIO-4 indicates association status. High means not associated with a network, Off indicates associated and Internet access is OK. GPIO-5 toggles when data is transferred.
6. **Keep out areas.** When designing your PCB avoid exposed trace and via beneath the module.
7. **Powering the module.** The WiFly module can be powered from either 3.0VDC batteries or 3.3VDC regulated power.

3.0VDC battery power

- Apply power to pin 20 (VDD-BATT)
- Short pin 17 (3.3V-REG-OUT) to pin 18 (3.3V-REG-IN) (battery boost mode)
- 150mA of current at 3.3V available for external devices on pin 21 when in battery boost mode.

3.3 VDC power

- Apply power to pin 20(VDD-BATT) and pin 21 (VDD-IN)
- Connect pin 18 (3.3V-REG-IN) to ground and leave pin 17 (3.3V-REG-OUT) unconnected.

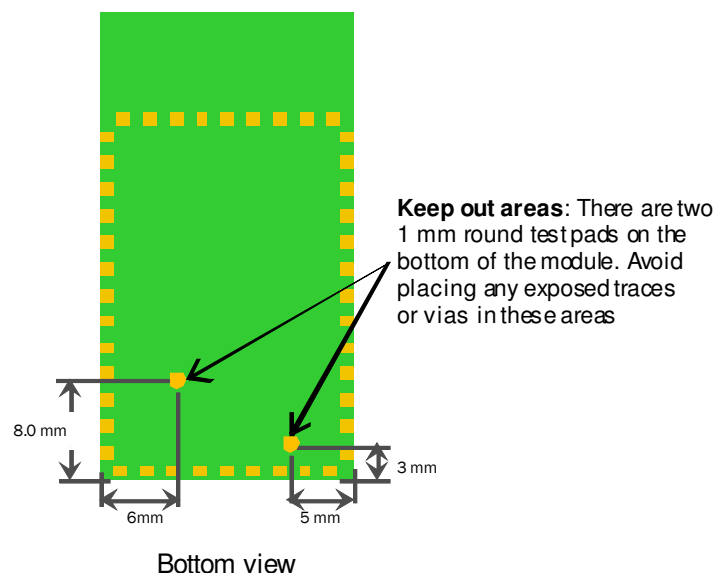

Keep out areas: There are two 1 mm round test pads on the bottom of the module. Avoid placing any exposed traces or vias in these areas

8. Achieving lowest power in sleep mode

To achieve the lowest power consumption (4uA) in sleep mode connect a weak pull down (100K resistor to GND) on the following pin.

Pin 22 - DMA-TX

If GPIO-8 through GPIO-4 are being used to drive an output, connect a 100k pull down resistor. Any GPIOs not used (No connect) can be left floating.

- Pin 25 - GPIO-8**
- Pin 26 - GPIO-7**
- Pin 27 - GPIO-6**
- Pin 28 - GPIO-5**
- Pin 29 - GPIO-4**

Other GPIO lines: No pulldown needed, internal pulldown (80K) already on chip.

The power consumption in sleep mode without these signals connected to a pull down is 655uA

9. **Sensor Interfaces.** Inputs must not exceed 1.2V. Sensitivity saturates at 400 mV.
10. **Adhoc mode and Restoring Factory Settings.** Adhoc mode is controlled through GPIO-9. It is a good idea to connect pin 24, GPIO-9 to a switch or jumper connected to a pull up. When GPIO-9 is driven high at power up the module will be in Adhoc mode. If GPIO-9 is then toggled low 5 times, the initial factory default configuration will be RESTORED. This is useful for cases where the module is mis-configured and is no long responding.

Compliance Information

FCC	ID U3O-G2M5477 Part 15.247
IC	(canada) RSS-210
CE	EU ID # 0681
REG	U9M20901-1000-C
RADIO	EN 300328 V1.7.1 (10/2006)
EMC	EN 301489-1 V1.8.1 (04/2008), EN 301489-17 V1.3.2 (04/2008)
SAFETY	EN 60950-1:2001+A11:2004
RoHs	Compliant

Ordering Information

Part Number	Description
RN-131G	Industrial Temperature (-30 to + 85 C) With chip antenna and U.FL connector
RN-131C	Commercial Temperature (0 to + 70 C) With chip antenna and U.FL connector

RN-131G-EVAL	Development Kit for the RN-131G (Includes the RN-131G module)
RN-134	SuRFboard carrier PCB for RN-131, RS-232, LEDs, power regulator. Sensor connections
RN-SMA4-RP	4" external antenna with reverse polarity SMA connector. Used with RN-UFL-SMA6
RN-UFL-SMA6	6 inch cable with U.FL connector on one end and SMA on the other
For other configurations, contact Roving Networks directly.	

Visit <http://www.rovingnetworks.com> for current pricing and a list of distributors carrying our products.

Copyright © 2009 Roving Networks. All rights reserved.

Roving Networks reserves the right to make corrections, modifications, and other changes to its products, documentation and services at any time. Customers should obtain the latest relevant information before placing orders and should verify that such information is current and complete.

Roving Networks assumes no liability for applications assistance or customer product design. Customers are responsible for their products and applications using Roving Networks components. To minimize the risks associated with customer products and applications, customers should provide adequate design and operating safeguards.

Roving Networks products are not authorized for use in safety-critical applications (such as life support) where a failure of the Roving Networks product would reasonably be expected to cause severe personal injury or death, unless officers of the parties have executed an agreement specifically governing such use.

All other trademarks are property of their respective owners.