

Class 1 Bluetooth® Module



Features

- Supports Bluetooth 2.1/2.0/1.2/1.1 standards
- Class1, up to 15dBm(RN21) (100meters)
- Bluetooth v2.0+EDR support
- Postage stamp sized module, 15.4mm x 22mm x 1.85mm
- UART (SPP or HCI) and USB (HCI only) data connection interfaces
- Sustained SPP data rates - 240Kbps (slave), 300Kbps (master)
- HCI data rates - 1.5Mbps sustained, 3.0Mbps burst in HCI mode
- 8MB on board flash
- HCI mode, or SPP/DUN software stacks
- Embedded Bluetooth stack profiles (*requires no host stack*): include GAP, SDP, RFCOMM and L2CAP protocols, with SPP and DUN profile support.
- Secure and robust link, FHSS, 128 bit encryption, error correction and guaranteed packet delivery.
- Built in software stack for auto-discovery, auto-connect, and instant cable modes.

Applications

- Cable replacement
- Barcode scanners
- Measurement and monitoring systems
- Industrial sensors and controls
- Medical devices
- Asset tacking

Description

The RN21 Bluetooth module is perfect for embedded applications where the Bluetooth radio must be located within a chassis. The small form factor and external antenna allow the RN21 to fit into many diverse applications. The straightforward hardware interface, castellated pads and complete software stack provides makes it easy and reliable to design into your end product. The RN21 provides a low power, high performance Bluetooth module that supports multiple protocols, including Enhanced Data Rate (EDR). The RN21 is the solution for developers needing to add wireless capability to their product but can not afford to spend significant time and money developing Bluetooth specific hardware and software.

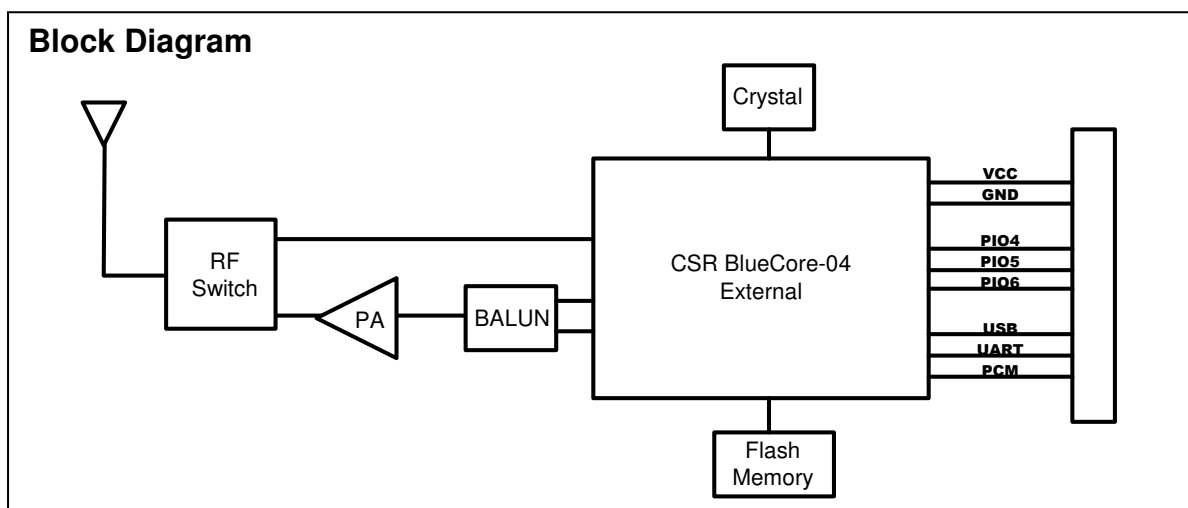

Overview

- Baud rate speeds: 1200bps up to 921Kbps, non-standard baud rates can be programmed.
- Class 1 radio, 330' (100m) distance, 12dBm output transmitter, -80dBm typical receive sensitivity
- Frequency 2402 ~ 2480MHz,
- FHSS/GFSK modulation, 79 channels at 1MHz intervals
- Secure communications, 128 bit encryption
- Error correction for guaranteed packet delivery
- UART local and over-the-air RF configuration
- Auto-discovery/pairing requires no software configuration (instant cable replacement).
- Auto-connect master, IO pin (DTR) and character based trigger modes

Environmental Conditions

Parameter	Value
Temperature Range (Operating)	-40 °C ~ 85 °C
Temperature Range (Storage)	-40 °C ~ 85 °C
Relative Humidity (Operating)	≤90%
Relative Humidity (Storage)	≤90%

Electrical Characteristics

Parameter	Min	Typ.	Max.	Unit
Supply Voltage (DC)	3.0	3.3	3.6	V
RX Supply Current		35	60	mA
TX Supply Current		65	100	mA
Average power consumption				
Standby/Idle (default settings)		25		mA
Connected (normal mode)		30		mA
Connected (low power Sniff)		8		mA
Standby/Idle (deep sleep enabled)	250uA	2.5		mA

Radio Characteristics

Parameter	Freq. (GHz)	Min	Typ	Max	Bluetooth Specification	Units
Sensitivity @ 0.1%BER	2.402	-	-80	-86	≤ -70	dBm
	2.441	-	-80	-86		dBm
	2.480	-	-80	-86		dBm
RF Transmit Power	2.402	15.0	16.0		≤ 15	dBm
	2.441	15.0	16.0			dBm
	2.480	15.0	16.0			dBm
Initial Carrier Frequency Tolerance	2.402	-	5	75	75	kHz
	2.441	-	5	75		kHz
	2.480	-	5	75		kHz
20dB bandwidth for modulated carrier		-	900	1000	≤ 1000	kHz
Drift (Five slots packet)		-	15	-	40	kHz
Drift Rate		-	13	-	20	kHz
Δf _{1avg} Max Modulation	2.402	140	165	175	>140	kHz
	2.441	140	165	175		kHz
	2.480	140	165	175		kHz
Δf _{2avg} Min Modulation	2.402	140	190	-	115	kHz
	2.441	140	190	-		kHz
	2.480	140	190	-		kHz

Pin Description

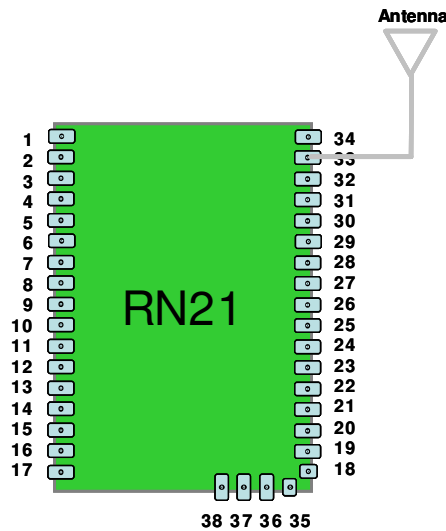

Pin	Name	Description	Default
1	GND		
2	NC	RF pad keep all traces and planes clear.	
3	GND		
4	AD0	Optional Analog input channel	Not used
5	AD1	Optional Analog input channel	Not used
6	Reset	Input to RN21	Active HIGH
7	SPI_MISO	Programming only	No Connect
8	SPI_CSB	Programming only	No Connect
9	SPI_CLK	Programming only	No Connect
10	SPI_MOSI	Programming only	No Connect
11	UART_CTS	UART input, if set HIGH, disables transmitter	Low level input to RN21
12	UART_TX	UART Transmit output	High level output from RN21
13	UART_RTS	UART output, goes HIGH to disable host transmitter	Low level output from RN21
14	UART_RX	UART Receive Input	Input to RN21 with pullup
15	NC		
16	VCC 3.3V	Input	
17	GND		
18	PCM_OUT	PCM interface	No Connect
19	PCM_SYNC	PCM interface	No Connect
20	PCM_IN	PCM interface	No Connect
21	PCM_CLK	PCM interface	No Connect
22	USB+	USB port	Pull up 1.5K when active
23	USB-	USB port	
24	PIO7	IO (HIGH= force 9600 baud), low = 115K baud	Input to RN21 with weak pulldown
25	PIO6	IO (HIGH=AUTO MASTER)	Input to RN21 with weak pulldown
26	PIO5	Status: toggles based on state, LOW on connect	Output from RN21
27	PIO4	To set Factory defaults start HIGH, then toggle 3x	Input to RN21 with weak pulldown
28	PIO3	Auto discovery = HIGH	Input to RN21 with weak pulldown
29	PIO2	High when connected, Low otherwise	Output from RN21
30	NC		
31	NC		
32	GND	Antenna ground	
33	RF_OUT	To external antenna	Output from RN21
34	GND	Antenna ground	
35	PIO8	IO (RF data/config LED option)	Output from RN21
36	PIO9	IO	Input to RN21 with weak pulldown
37	PIO10	IO (remote DTR signal)	Input to RN21 with weak pulldown
38	PIO11	IO (remote RTS signal)	Input to RN21 with weak pulldown

Digital I/O Characteristics

$2.7V \leq VDD \leq 3.0V$	Min	Typ.	Max.	Unit
Input logic level LOW	-0.4	-	+0.8	V
Input logic level HIGH	0.7VDD	-	VDD+0.4	V
Output logic level LOW	-	-	0.2	V
Output logic level HIGH	VDD-0.2	-	-	V
All I/O's default to weakpull down	+0.2	+1.0	+5.0	μA

Typical Application Circuit

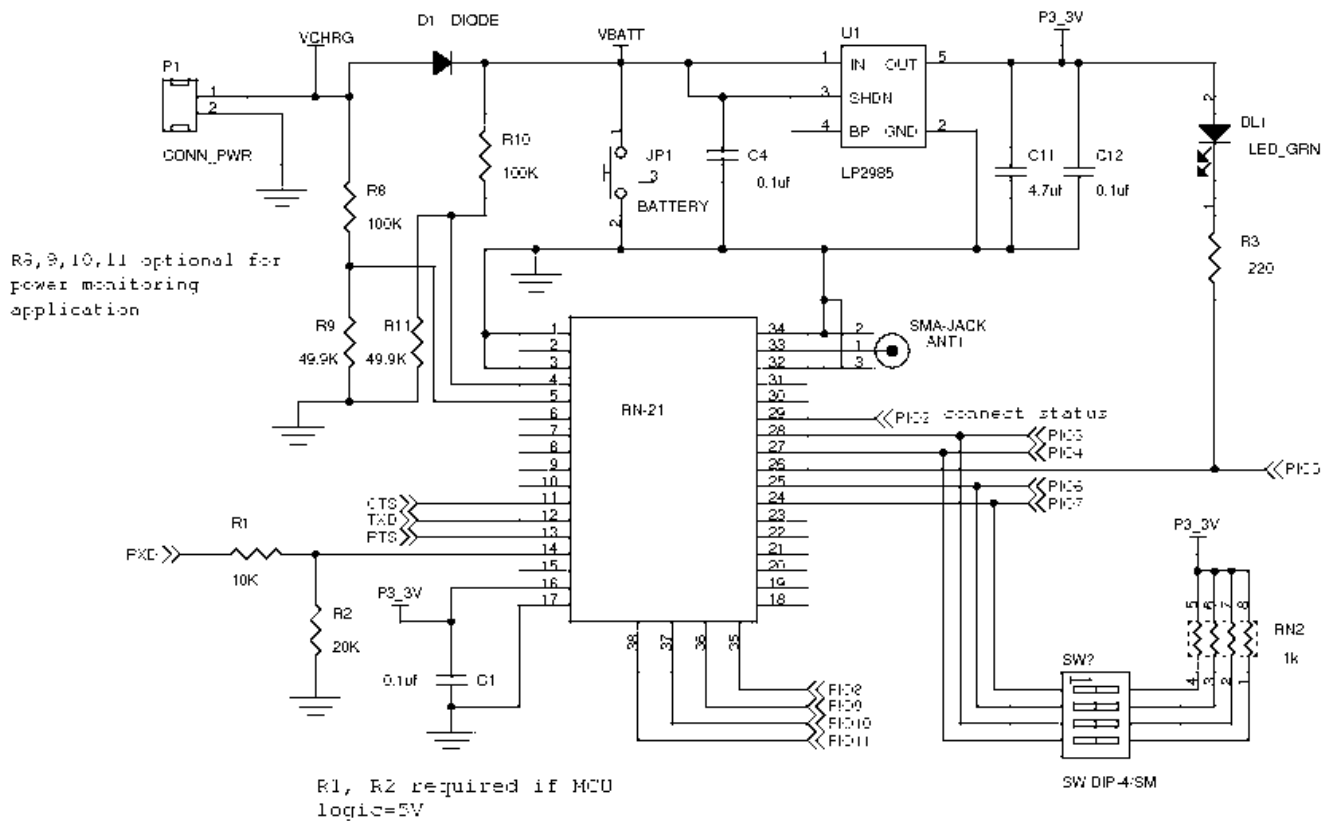

Module Dimensions

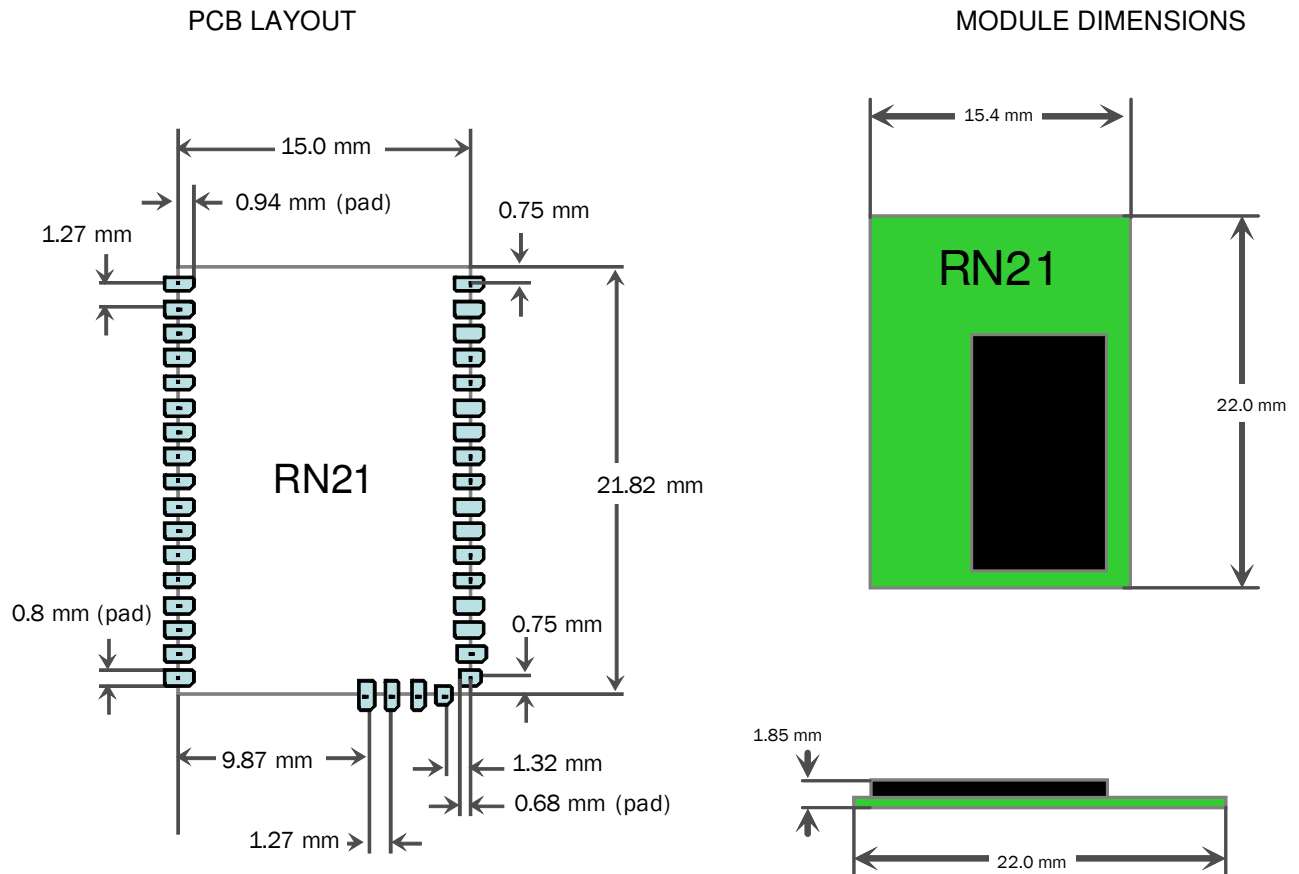

Design Concerns

- Reset circuit.** RN-21 contains a 1k pull-down to GND, the polarity of reset is active HIGH. A power on reset circuit with delay is OPTIONAL on the reset pin of the module. It should only be required if the input power supply has a very slow ramp, or tends to bounce or have instability on power up. Often a microcontroller or embedded CPU IO is available to generate reset once power is stable. If not, there are many low cost power supervisor chips available, such as MCP8010.
- Factory reset PIO4.** It is a good idea to connect this pin to a switch, or jumper, or resistor, so it can be accessed. This pin can be used to reset the module to FACTORY DEFAULTS and is often critical in situations where the module has been misconfigured.
- Connection status.** PIO5 is available to drive an LED, and blinks at various speeds to indicate status. PIO2 is an output which directly reflects the connection state, it goes HIGH when connected, and LOW otherwise.
- HCI mode.** The RN21 module must be loaded with special firmware to run in HCI mode. When in HCI mode the standard SPP/DUN profiles are disabled.

5. **Using SPI bus for flash upgrade.** While not required, this bus is very useful for configuring advanced parameters of the Bluetooth modules, and is required for upgrading the firmware on modules. The suggested ref-design shows a 6pin header which can be implemented to gain access to this bus. A minimum-mode version could just use the SPI signals (4pins) and pickup ground and VCC from elsewhere on the design.

6. **Antenna Design.** The pattern from the rf_out terminal pad should be designed with 50ohms impedance and traced with straight lines. (see diagram to the right) The rf_out signal line should not run under or near the RN21 module. The GND plane should be on the side of the PCB which the module is mounted. The GND should be reinforced with through-hole connections and other means to stabilize the electric potential.

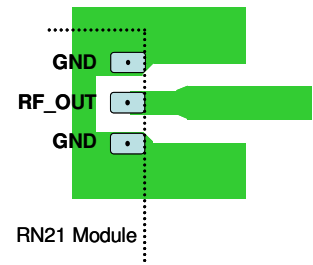

Recommended on-chip antenna is Yageo SMT high performance chip for Bluetooth/802.11b/g 2.45GHz (3.6mm x 7.2mm)

7. Soldering Reflow Profile.

- Lead-Free Solder Reflow
- Temp: 230 degree C, 30-40 seconds, Peak 250 degree C maximum.
- Preheat temp: 165 +- 15 degree C, 90 to 120 seconds.
- Time: Single Pass, One Time

Ordering Information

Part Number	Description
RN-21	Standard firmware (SPP/DUN Master and Slave)
RN-21-H	HCI firmware (HCI over H4 UART)
RN-21-U	USB firmware (HCI over USB port, slave device at 12Mbps rate)
For other configurations, contact Roving Networks directly.	

Visit <http://www.rovingnetworks.com> for current pricing and a list of locations selling Roving Networks Products.

Copyright © 2009 Roving Networks. All rights reserved.

The Bluetooth trademark and logo are registered trademarks of Bluetooth SIG, Inc. All other trademarks are property of their respective owners.

Roving Networks reserves the right to make corrections, modifications, and other changes to its products, documentation and services at any time. Customers should obtain the latest relevant information before placing orders and should verify that such information is current and complete.

Roving Networks assumes no liability for applications assistance or customer's product design. Customers are responsible for their products and applications which use Roving Networks components. To minimize customer product risks, customers should provide adequate design and operating safeguards.

Roving Networks products are not authorized for use in safety-critical applications (such as life support) where a failure of the Roving Networks product would reasonably be expected to cause severe personal injury or death, unless officers of the parties have executed an agreement specifically governing such use.